

INSTALLATION INSTRUCTIONS

Rev. 1

MODEL NO. 88051

Hardware Kit #112544

APPLICATION:

**2001-06 Honda Pilot
2003-08 Acura MDX**

WARNING

Although this hitch is designed to safely tow its rated load, we recommend that you consult your vehicle owner's manual for possible manufacturer's recommendations or limitations. Always follow the manufacturer's installation instructions and always install on the specified vehicle. Before installing hitch, check that the attachment points are in good condition.

Failure to follow these guidelines will void warranty. Any modifications to this hitch will void warranty.

CLASS III

WEIGHT CARRYING HITCH CAPACITY

**3500 LBS. MAXIMUM TRAILER WEIGHT
350 LBS. MAXIMUM TONGUE WEIGHT**

WEIGHT DISTRIBUTING HITCH CAPACITY

**5000 LBS. MAXIMUM TRAILER WEIGHT
500 LBS. MAXIMUM TONGUE WEIGHT**

Trailer brakes are recommended for
towing loads in excess of 1500 lbs.

COMPLETE PARTS LIST

<i>Part</i>	<i>Description</i>	<i>Quantity</i>
1.	Receiver Assembly	(1)
<i>HARDWARE KIT #112544</i>		
2.	373202 12mm x 1.25 x 40mm Hex Bolt Cl 10.9	(4)
3.	455008 10mm x 1.25 x 30mm Hex Bolt Cl 10.9	(2)
4.	373005 1/2 Conical Washer	(4)
5.	188703 7/16 Flatwasher	(2)
6.	187903 7/16 Lockwasher	(2)
7.	112545 Instruction Sheet	(1)
<i>T Connector</i>		
8.	30002035 T Connector Assembly	(1)

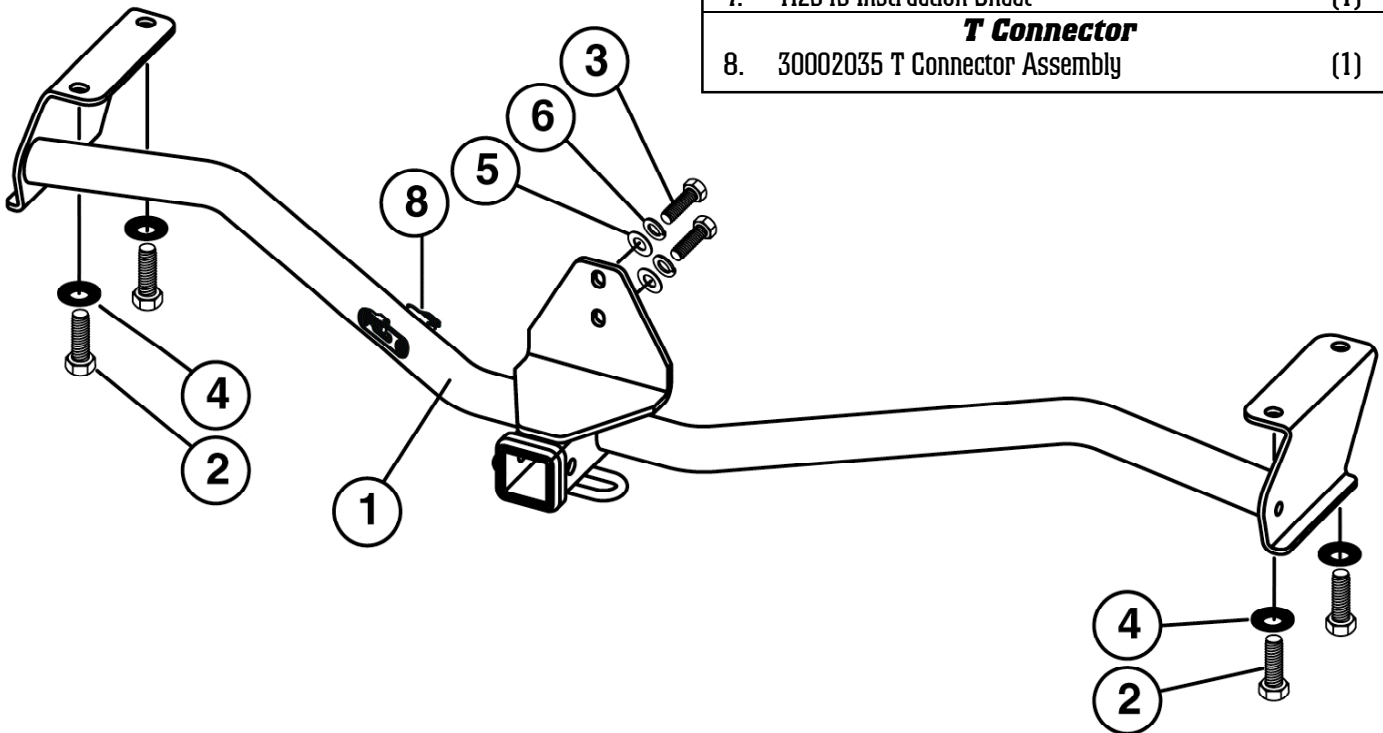

1. ***Read instructions thoroughly before beginning.***
 2. Open the rear cargo door of the vehicle and remove the plastic threshold and set aside.
 3. The vehicles harness connector is located on the left (driver's) side (Fig. 1). Locate and remove the large black grommet that is on the same mounting surface as the vehicle harness (Fig. 2).
 4. From beneath the vehicle, locate and remove a second grommet of similar size and shape, positioned directly below the grommet removed in step three (Fig. 3).
 5. Starting from the underside of the vehicle route the hitch wiring harness up through both holes and into the rear cargo area. Attach the hitch wiring harness connector to the vehicles connector, making sure the locking tab is fully engaged.
 6. Mount the hitch wiring harnesses black box to a secure location on the underside of the vehicle using provided cable ties and double sided tape.
- Note:*** Prior to attachment, ensure the mounting surface is clean and free of any debris
7. Using a utility knife carefully slit and replace both factory grommets allowing for the hitch wiring harness to pass through without contacting the edges of the holes (Fig. 4).



Fig. 1

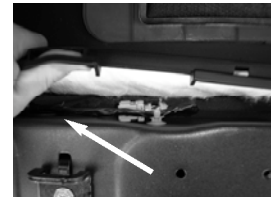

Fig. 2



Fig. 3

Hitch Installation

1. Remove the tow hook from bottom of the drivers side vehicle frame. See Illustration 1. Discard the attaching bolts and tow hook.
2. Remove the two rubber muffler hangers from their attaching rods on the body. See Illustration 2. This will allow the muffler to drop slightly which will make hitch installation easier. Muffler will be put back up in its original position after hitch is installed.

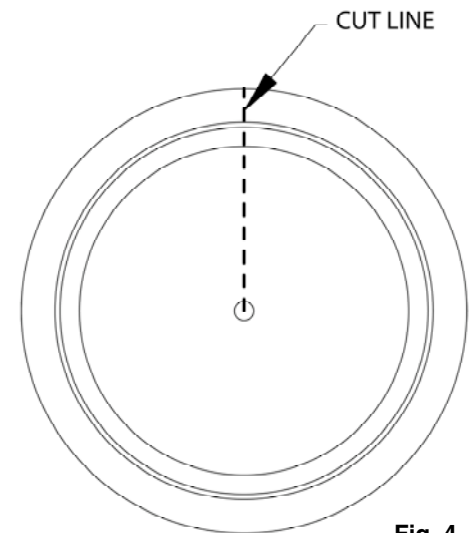
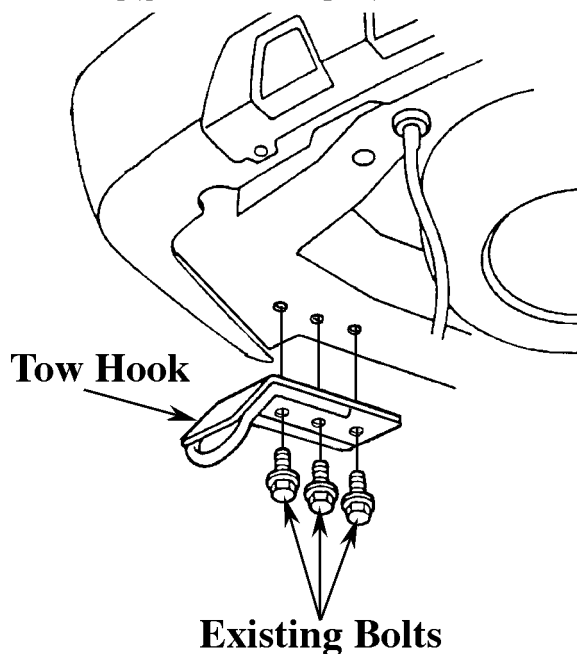

Fig. 4

ILLUSTRATION 1



Rubber Muffler Hangers

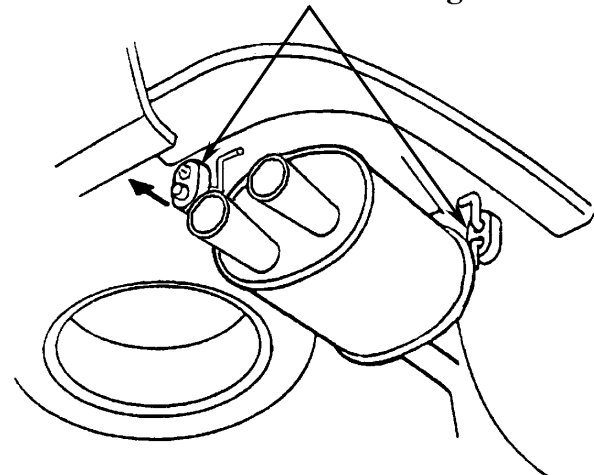
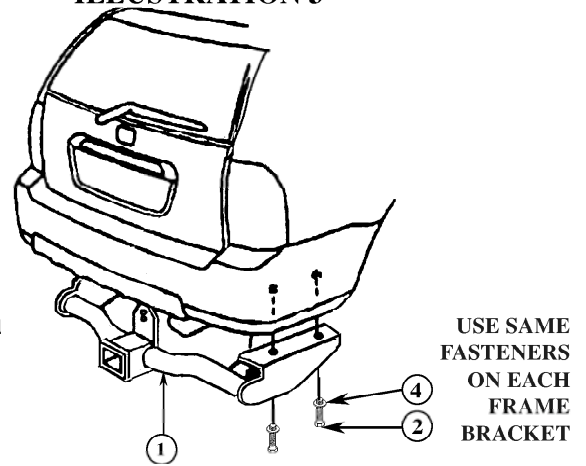

ILLUSTRATION 2

ILLUSTRATION 3

3. Position the receiver assembly #1 up against bottom of vehicle frame and bolt loosely in place with 12mm fasteners as shown on Illustration 3. Do not tighten attachment bolts at this time.
4. Attach the vertical two hole plate at center of receiver assembly to the forward side of the bumper beam, with the 10mm fasteners supplied with the hitch. There are two 10mm weldnuts in the bumper beam at this location.
5. Tighten the 12mm bolts to 75 ft. lbs. torque, and the 10mm bolts to 42 ft. lbs. torque. Failure to tighten bolts as described may result in fastener loss or failure. See Illustration 4
6. Re-attach the rubber muffler hangers to their attaching rods.
7. Plug the remaining connector of the installed harness into the mating connector on the inward side of the hitch once installed. Press the connectors firmly together, ensuring that the locking tabs engage.
8. Confirm correct operation of the 4-Flat connector by using a test light or a properly equipped trailer.
9. Secure any loose wires under the vehicle using cable ties. Return the tail light assembly, trim panel, cargo cover, cargo net and threshold to their original positions.



WARNING: Use only a 5/8" diameter hitch pin with locking device to secure a ball mount in this receiver.

WARNING: Be sure to check the hitch pin and hair pin for positive locking placement before towing trailer.

NOTE: Some states require a clear view of license plates. Remove trailer ball and/or ball mount when not in use if it restricts view.

ILLUSTRATION 4

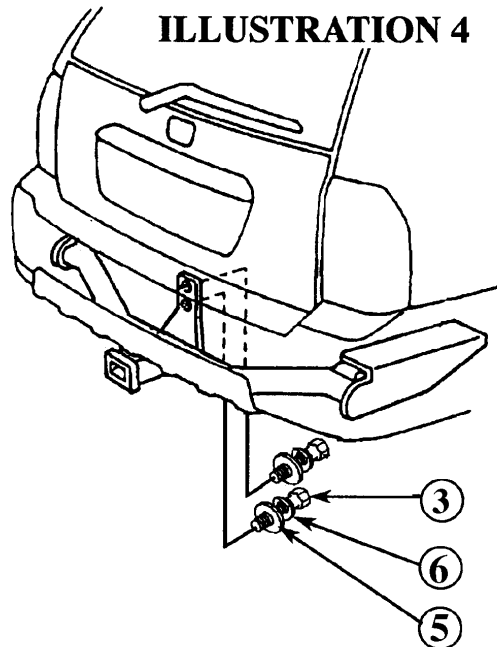

For information regarding the installation of this product, go to: www.towingsupport.com
or Email us at: tech@towingsupport.com or Call our Technical Support Team at: 1-800-344-3230

This product complies with regulation V-5, C.S.A Standard D-264 and safety requirements for connecting devices and towing systems of the State of New York