

INSTALLATION INSTRUCTIONS

MODEL NO. 65690

APPLICATION: 1978-81 Buick Century Psgr. & S/W 1978-88 Oldsmobile Cutlass Psgr. (excl. Ciera)
 1988-96 Buick Regal 2Dr. Coupe 1982-86 Pontiac Bonneville Psgr.
 1978-84 Buick Regal 4Dr. Psgr. 1982-83 Pontiac Bonneville S/W
 1978-87 Chevrolet El Camino 1978-87 Pontiac Grand Prix
 1978-88 Chevrolet Monte Carlo (exc SS) 1978-81 Pontiac LeMans Safari S/W
 1978-83 Chevrolet Malibu Psgr. 1978-81 Pontiac LeMans, Grand Am Psgr.
 1978-87 GMC Caballero 1978-83 Oldsmobile Cutlass Cruiser & S/W

Some models of the Monte Carlo with dual exhaust may require tailpipe modifications to install hitch

WARNING

Although this hitch is designed to safely tow its rated load, we recommend that you consult your vehicle owner's manual for possible manufacturer's recommendations or limitations. Always follow the manufacturer's installation instructions and always install on the specified vehicle. Before installing hitch, check that the attachment points are in good condition.

Failure to follow these guidelines will void warranty. Any modifications to this hitch will void warranty.

WEIGHT CARRYING HITCH CAPACITY

**3500 LBS. MAXIMUM TRAILER WEIGHT
 350 LBS. MAXIMUM TONGUE WEIGHT**

Trailer brakes are recommended for towing loads in excess of 1500 lbs.

COMPLETE PARTS LIST

| Part | Description | Quantity |
|------|------------------------------|----------|
| 1. | Hitch Assembly | (1) |
| 2. | 1860-03 3/8 Hex Nut | (2) |
| 3. | 1848-03 3/8 Flatwasher | (2) |
| 4. | 1825-03 3/8 Lockwasher | (2) |
| 5. | 2192-03 HD 3/8 Flatwasher | (4) |
| 6. | 1886-03 5/16 Flatwasher | (2) |
| 7. | 2537-03 8mm x 35mm Hex Bolt | (2) |
| 8. | 4441-03 3/8 x 1-1/2 Hex Bolt | (2) |
| 9. | 1002-03 3/8 Spacer Plate | (2) |
| 10. | 1917-04 Ball Mount | (1) |
| 11. | 1083-04 Hitch Pin | (1) |
| 12. | 1335-03 Hair Pin | (1) |
| 13. | 4751-04 Receiver Cover | (1) |

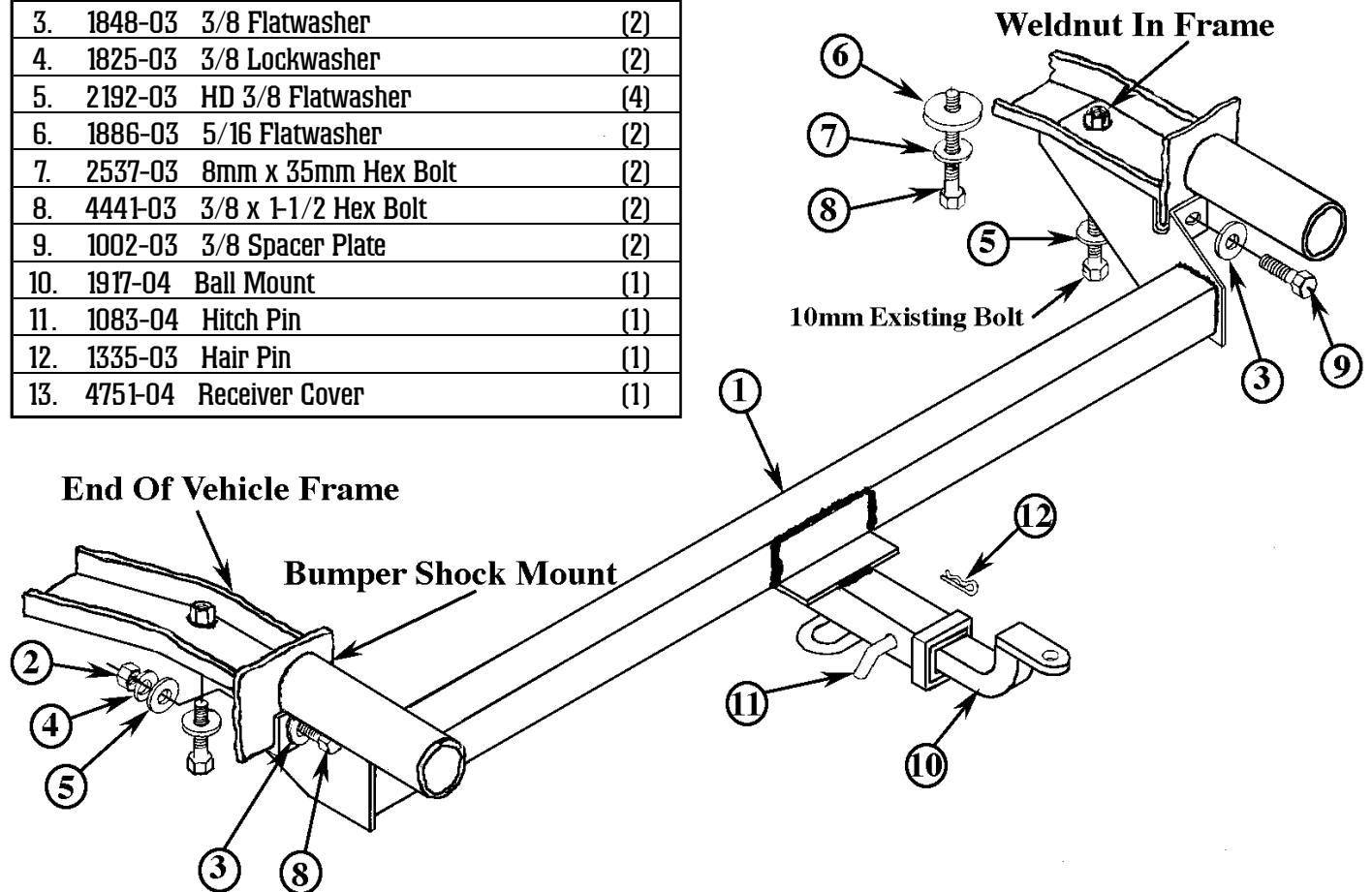

1. Remove the lower inside bolts from the body side flange of each bumper shock mount. Discard the fasteners just removed. Check the hole size in each flange. They must accept a 3/8" bolt. Drill out to 3/8" diameter if necessary.
2. Remove the existing metric bolts from the bottom of the vehicle side frame located approximately 6-1/2" from the end of each frame. If these bolts are 10mm, they should be saved. If they are 8mm diameter, discard them. Longer 8mm bolts are supplied in this kit.
3. Position the hitch assembly #1 against the bottom of the vehicle frame with slot in frame bracket in line with the existing weldnuts in vehicle frame where bolts were previously removed. If 10mm bolts were removed, use these bolts to install hitch at this location. However, place one heavy duty 3/8" flatwasher #5 on each bolt before installing it in the frame. If 8mm bolts were previously removed, use the longer 8mm bolts #7, the 5/16" flatwashers #6 and the heavy duty 3/8" flatwashers #5 at each attachment point.
4. Place a 3/8" spacer plate #9 between the hitch mounting tab and the shock mount if a gap exists. Bolt tab to shock mount flange with 3/8" fasteners as illustrated.
5. Tighten the 8mm bolts to 25 ft. lbs. torque, the 10mm bolts to 42 ft. lbs. torque and the 3/8" fasteners to 30 ft. lbs. torque. Failure to tighten bolts as described may result in fastener loss or failure.
6. Slide the ball mount #10 into hitch receiver and secure with the hitch pin #11 and hair pin #12.

WARNING: Use only the ball mount supplied with this hitch. Use this hitch only as a weight carrying hitch.

DO NOT use with any type of weight distributing hitch.

WARNING: If this hitch is used with any auxiliary load carrying product, such as bicycle or cargo carriers, the loaded weight must not exceed 200 lbs. including the weight of the carrier. The loaded carrier weight with the extended leverage may damage hitch and/or attachment points on vehicle.

WARNING: Be sure to check the hitch pin and hair pin for positive locking placement before towing trailer.

NOTE: When hitch is not being used, remove the ball mount from receiver and place receiver cover into receiver opening.

NOTE: Some states require a clear view of license plates. Remove trailer ball and/or ball mount when not in use if it restricts view.

For information regarding this product, or our warranty, contact your dealer or write to:
"CUSTOMER SERVICE MANAGER" P.O. Box 850, Lodi, CA 95241

This product complies with regulation V-5, C.S.A Standard D-264 and safety requirements for connecting devices
and towing systems of the State of New York

65690