

INSTALLATION INSTRUCTIONS

MODEL NO. 61080

APPLICATION: 1978-81 Buick Century (all) 1978-80 Buick Regal (all) 1982-83 Buick Regal Sedan & S/W 1978-79 Chevrolet Malibu Sedan 1978-84 Chevrolet Malibu S/W 1978-87 Chevrolet El Camino	1978-80 Oldsmobile Cutlass (all) 1981-87 Oldsmobile Cutlass Sedan 1978-81 Pontiac Grand Am/LeMans Sedan 1978-87 Pontiac Grand Prix 1982-86 Pontiac Bonneville Sedan 1978-87 GMC Caballero
--	--

WARNING

Although this hitch is designed to safely tow its rated load, we recommend that you consult your vehicle owner's manual for possible manufacturer's recommendations or limitations. Always follow the manufacturer's installation instructions and always install on the specified vehicle. Before installing hitch, check that the attachment points are in good condition.

Failure to follow these guidelines will void warranty. Any modifications to this hitch will void warranty.

HITCH CAPACITY

**2000 LBS. MAXIMUM TRAILER WEIGHT
200 LBS. MAXIMUM TONGUE WEIGHT**

Trailer brakes are recommended for towing loads in excess of 1500 lbs.

DO NOT use this hitch with any type of cargo carrier. 2 Bike maximum Bicycle Carriers can be used but **MUST** be Used with Valley 90730 Support Strap or Similar Strap to Tie Top of Rack Back to Vehicle.

COMPLETE PARTS LIST

Part	Description	Quantity
1.	3709-01 Draw Bar	(1)
2.	1328-02 Chain Clip-Yoke	(1)
3.	4659-05 Yoke	(1)
4.	1001-03 Plate	(2)
5.	1936-03 7/16 Round Spacer	(8)
6.	1861-03 7/16 Hex Nut	(6)
7.	1879-03 7/16 Lockwasher	(6)
8.	1845-03 7/16 Short U-Bolt	(2)

Part	Description	Quantity
9.	1888-03 1/2 Flatwasher	(1)
10.	1880-03 1/2 Lockwasher	(2)
11.	1862-03 1/2 Hex Nut	(2)
12.	1837-03 1/2 x 1-3/4 Hex Bolt	(1)
13.	1836-03 1/2 x 1-1/2 Hex Bolt	(1)
14.	4444-03 7/16 Long U-Bolt	(1)
15.	1830-03 7/16 x 1-1/2 Hex Bolt	(2)
16.	1887-03 7/16 Flatwasher	(2)

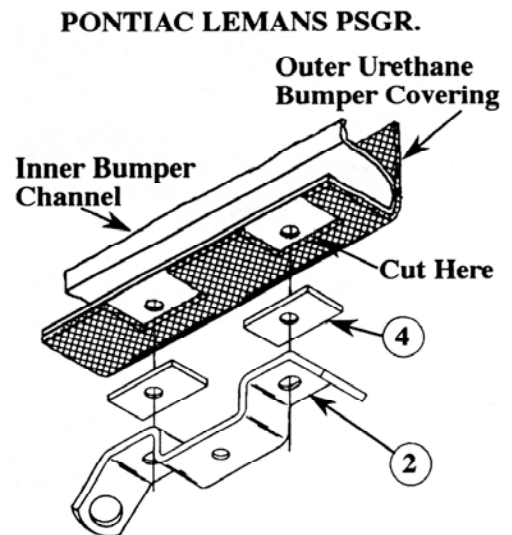
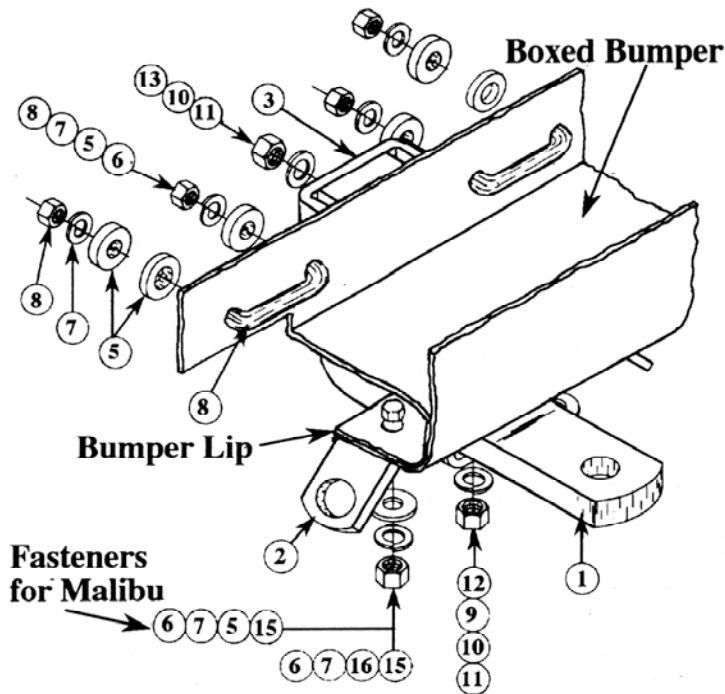

ILLUSTRATION 2

1. Assemble draw bar #1, chain clip-yoke #2 and Yoke #3, as illustrated. The Malibu passenger application requires that the draw bar be bolted to the backside of yoke #3.
2. Center the hitch assembly on the lower lip and backside of the bumper. On some applications, bolts in the bumper will interfere with the draw bar and must be removed. A wiring harness may also need to be relocated for hitch clearance.
3. Using holes in the hitch parts as guides, mark two attachment points on the lower lip of the bumper and two points on the backside of the bumper reinforcement.

NOTE: Some applications may have vertical supports inside the reinforcement which will interfere with the U-Bolt placement. See Illustration 3 for U-Bolt alignment directions.
4. To make drilling of the backside of bumper easier, on some applications, it is suggested that the bumper be removed from the shock mounts at the ends of the vehicle frame. Remove four nuts from each bumper mount plate and lift bumper off the brackets. Hitch may be completely installed on bumper before the bumper is reinstalled on vehicle.
5. After drilling the four previously marked attachment holes, place the leg of the short U-Bolt #9 at the drilled hole on the backside of the bumper reinforcement and mark the second attachment hole to the outside of the first hole. Use the same procedure for the remaining short U-Bolt. Drill the remaining attachment holes and insert the U-Bolts as illustrated. Be sure to place the round spacers #5 on U-Bolt legs as illustrated.
6. On Pontiac LeMans application, a small section of the outer urethane bumper fascia must be cut away before attaching the hitch. Place one spacer #4, centered over the previously drilled holes in bumper lip and cut around these spacers so that they will rest against the inner steel bumper channel.
7. Bolt the chain clip-yoke #2 to the bumper lip on all applications except the Malibu, using the bolts #15 and flatwashers #16. On Malibu applications, use the long U-Bolts #14 inserted into the box bumper section as illustrated.
8. Tighten all 1/2" bolts to 75 ft. lbs. torque and 7/16" to 35 ft. lbs. torque. Failure to tighten bolts as described may result in fastener loss or failure.

WARNING: Use only the ball mount supplied with this hitch. Use this hitch only as a weight carrying hitch.

DO NOT use with any type of weight distributing hitch.

WARNING: Be sure to check the hitch pin and hair pin for positive locking placement before towing a trailer.

NOTE: When hitch is not in use, remove ball mount from receiver and place the receiver cover into receiver opening.

NOTE: Some states require a clear view of license plates. Remove trailer ball and/or ball mount when not in use if it restricts view.

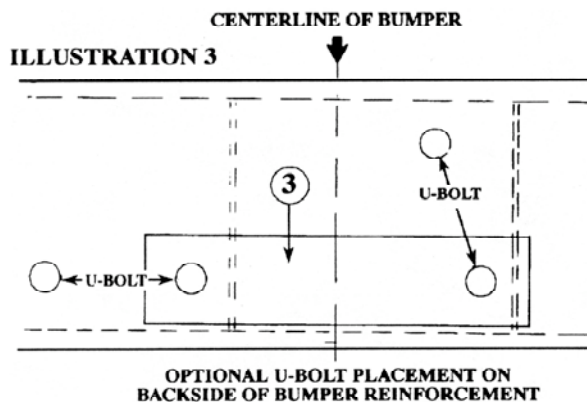

Note: Insert one leg of U-bolt into one 1/2" drilled hole and feed it around and out through the other 1/2" drilled hole.

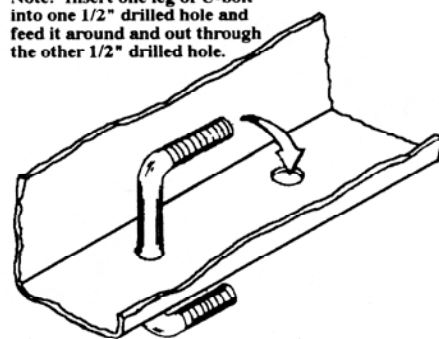

For information regarding this product, or our warranty, contact your dealer or write to:
 "CUSTOMER SERVICE MANAGER" P.O. Box 850, Lodi, CA 95241

This product complies with regulation V-5, C.S.A Standard D-264 and safety requirements for connecting devices and towing systems of the State of New York